



EFRA ANNUAL SECTION MEETING
HOTEL NH Wien Airport,
Vienna Austria
4-5th of November 2017

Minutes Large Scale

SATURDAY 4th of November 2017.

The meeting started at:

1. CHAIRMAN'S WELCOME

Mr Ian Oddie

The Large Scale Chairman opened the meeting at 13:43

2. APOLOGIES FOR ABSENCE

Apologies have been received from-

Zarko Vugo, Slovenia

Jeff Mersch, Luxembourg

Peter Leue, Germany

Member Countries presents, section subscription, allocations etc:

20 places are allocated according to App. 5-- 1.4

	Touring Cars			Formula	
1	Edoardo Repetti		1	Patrick Reints	
2	Viktor Bolsec		2	BLUM ANDREAS	
3	Joel Oskarsson		3	REINAHARD MARON	
4	Kevin Tolenaars		4	IVO DAY	
5	Søren Bang		5	COCCHI VALERIO	
6	Hessel Roskam		6	BORSONI MAURIZIO	
7	Marco Harleman		7	Adriaan WELLNER	
8	Søren Jeppesen		8	ALBERTI CLAUDIO	
9	David Hansen		9	Ewald PROCHASKA	
10	VESELI DARIO		10	Edoardo REPETTI	
11	Markus Feldmann		11	PORRO CESARE	
12	FOLMAN PATRIK		12	Werner KLUG	
13	Giovanni Verbrugge		13	MAGGI MASSIMO	
14	GRIGIC MARKO		14	TULLI ALESSANDRO	
15	Guido Ruster		15	ROSSIGNOLI GIUSEPPE	
16	Maximilian Hornig		16	DADA MARIO	
17	Jeffrey van Wijk		17		
18	Marco Weigerding		18		
19	Zettel Thomas		19		
20	Marius Hetland		20		

COUNTRY	PRESENT	F1	TC	Short Course	EC2WD Off road	EC 4WD Offroad	
AUSTRIA	Ewald Prochaska	2	3	1	1	4	
BELARUS							
BELGIUM			3				

BULGARIA							
CROATIA	Hrvoje Stegmayer		7			1	
CZECH REP.	Ivo Day						
DENMARK	Søren Jeppesen		4		8	6	
ESTONIA					2	2	
FINLAND						10	
FRANCE	Philipp Bertrand	5	12	5	6	6	
GERMANY		3	18	7	8	15	
GREAT BRITAIN	Craig Orman	5	10	11		3	
GREECE							
HUNGARY							
IRELAND							
ITALY	Massimiliano Cerquetani	3	7				
LUXEMBOURG							
MONACO							
NETHERLANDS	Cor Roskam	1	10	5	5	10	
NORWAY	Chistina T. Nygaard		6				
POLAND							
PORTUGAL	César Coelho	4	2				
RUSSIA							
SLOVAK REP.							
SLOVENIA							
SPAIN		1	4		4		
SWEDEN			6				
SWITZERLAND	Ernesto Camponovo	1	10	5	8	10	
TURKEY							
TOTAL	11	25	102	34	42	67	

TotalEC Tourlaville 127

Total EC Fehring 143

Allocations can be changed till December 21th 2017.

Other persons present: Laszlo Gal

3. MINUTES OF 2016SECTION MEETING

November 2016— Vienna, Austria Matters arising from the minutes:

The minutes were checked and accepted as written at the AGM 2016.

Seconded by: Netherlands accepted unanimous

The following person was elected to check the minutes of this year: Craig Orman

4. CORRESPONDENCE RECEIVED

Only very minor problems were received during the year, all were resolved. The new online entry system for the EC's caused a few headaches for some federations but most seem to have it in hand now.

5. CHAIRMAN'S REPORT

2017 has been another successful year in the Large Scale section, 4 on road and 1 off road gp events and 3 European Championships combining 5 different class. A special congratulations to all the winners;-

European Champion On Road TC- Arnaldi, Bernard Alain ,France

European Champion On Road F1- Marti, Toni Gil,Spain

European Champion Off Road 4wd- Veseli, Dario,Croatia

European Champion Off Road 2wd- Walckiers, Ken ,Belgium

European Champion Off Road Short Course- Perry, Mathew,Great Britain

European Champion 40+ TC Harald Reitprecht

European Champion 40+ F1 Ivo Day

Gp Series TC- Edoardo Repetti, Italy

Gp Series F1- Patrick Reints, Netherlands

Most events ran very smoothly even though some were effected by the weather but overall it's been a great year with some great racing.

As always we need to look to the future and the purpose of the AGM each year is for everyone involved to steer the Large Scale section in the best direction to move forward, making the races even better and attracting new racers. This year we have 12 proposals, but having spoken to many racers at events throughout the year, there have been many fresh and interesting ideas that seem to have been lost after the events. Every racer should know that this is their organisation and they should be encouraged to put proposals into the AGM via their federations.

Most of the proposals this year are minor tweaks/corrections to existing rules, but we also have 2 for tyre controls and one to introduce electric large scale touring cars into the gp series. The world is a changing place and electric cars/technology is evolving very rapidly, we should embrace this new direction of our class, who knows where the future will take us.

6. PRESENTATIONS FOR APPLICATIONS EC 2019 AND GP'S 2018

The section has received the following applications to host coming EFRA events. These proposals have reached us in time, not other proposal will be accepted after distribution of the agenda.

Year/Date	Alt. Date	Status	Country	Venue
2018		GP	Switzerland	Lostallo
2018		GP	Italy	Cremona
2018		GP	Germany	Leipzig lowes pionts
2018		GP Off Road	Bulgaria	Vratza/Ledenica
2018		GP	Austria	Stöhring
2018		GP	Netherlands	Rucphen
2018		EC 40+	Switzerland	Lostallo
2019		WC	Portugal	Vila Real 10
2019		WC	Croatia	Zagreb 1
2019/20 ?		EC Off Road	Bulgaria	Vratza/Ledenica

Final Race calendar 2018

Year/Date	Alt. Date	Status	Country	Venue
2018	28-29.04.	GP TC F1	Netherlands	Rucphen
2018	19-20.05.	GP TC F1	Austria	Kirchberg
2018	23-24.06.	GP TC F1	Switzerland	Lostallo
2018	9-14.07.	EC TC/F1	France	Tourlaville
2018	23-28.07.	EC Off Road	Austria	Fehring
2018	25-26.08.	GP TC F1	Italy	Cremona
2018	10-15.09.	40+	Switzerland	Lostallo
2018	8-9, 09	GP Off Road	Bulgaria	Ledenica

Future Race calendar Championships

Year/Date	Alt. Date	Status	Country	Venue
2019		EC Off Road	Bulgaria	Vratza/Ledenica
		EC40+	Switzerland	Lostallo
2019		WC	Portugal	Vila Real 10

7. ALLOCATIONS

Allocations were made to each country as printed in the table form under item 2 on the agenda.
All Federations MUST confirm their FINAL Allocation Numbers for each event to the relevant Section Chairman by 21th. December LATEST.

8. RULE PROPOSALS

Note: The EFRA Committee has studied all received proposals and has come to an opinion over each one, The EFRA Section Chairman will inform the floor of such positions.

APPENDIX 5 LARGE SCALE I.C. TRACK RULES

THE RULE SHOULD BE AMENDED TO READ:

Existing Rule: 1.1.

There will be two annual events called European Championships to determine the European Champion in:

- a.) 1:5 Scale Touring Cars
 - b.) 1:6 Scale Off Road Cars 2WD + 4WD + Short Course
- Drivers can only enter one class at a European Championship. There will not be a 1:5 touring car European Championship event held in the same year as an IFMAR World Championship event held in Europe, the 4 EFRA GP's will determine the European Champion in Touring car and Formula 1 with the 3 best results counting.

Proposal:

There will be **three** annual events called European Championships to determine the European Champion in:

- a.) 1:5 Scale Touring **Cars and F1**
- b.) 1:6 Scale Off Road Cars 2WD + 4WD + Short Course
- c.) **1:5 Scale Touring cars and F1, 40+**

Drivers can only enter one class at a European Championship. There will not be a 1:5 touring car European Championship event held in the same year as an IFMAR World Championship event held in Europe, the 4 EFRA GP's will determine the European Champion in Touring car and Formula 1 with the 3 best results counting.

Remarks:

Minor changes/corrections. The F1 ec is now combined with the touring cars and we also have a 40+ ec.

Proposed by EFRA, Oddie Ian

Seconded by: ..Great Britain..... o Not Seconded

**The proposal: X Passed Unanimously o Passed with for, against and abstentions.
o Rejected with for, against and abstentions. o Amended**

THE RULE SHOULD BE AMENDED TO READ:

Existing Rule: 2.1.

Duration of the races: Free practice max: 8 minutes
Heats: 10 minutes (plus the last lap and time of the last lap)
Sub-finals min:15 minutes, max. 20 minutes up from the 1/32 final and 30 minutes for semi finals.
Final Saloon: 30 minutes (plus the last lap and time of the last lap)
Semi final Formula 1: 30 minutes, 1 single fuel stop (plus the last lap and time of the last lap)
Final Formula 1:50 minutes, 1 single fuel stop (plus the last lap and time of the last lap)

Proposal:

Duration of the races: Free practice max: 8 minutes
Heats: 10 minutes (plus the last lap and time of the last lap)
Sub-finals min:15 minutes, max. 20 minutes up from the 1/32 final and 30 minutes for semi finals.
Final Saloon: 30 minutes (plus the last lap and time of the last lap)

Semi final Formula 1: **25 minutes** (plus the last lap and time of the last lap)

Final Formula 1: **25 minutes** (plus the last lap and time of the last lap)

Remarks:

Change F1 semi final and main final to 25 minute duration. Removes the need for a mid race fuel stop (safety issue) and also makes the main final a race from start to finish rather than an endurance test of tyres.

Proposed by EFRA, Oddie Ian

Seconded by: NOMAC Not Seconded

The proposal: o Passed Unanimously o Passed with ..10.. for, .1... against and abstentions.

o Rejected with for, against and abstentions. o Amended

THE RULE IS NEW:

Existing Rule: **2.2.**

- a) The EFRA Christmas Tree will be used.
- b) All other drivers are allowed to race a sub-final.
- c) Sub-Finals: The first 3 drivers from each sub-final progress up to the next final.
Semi-final: The first 5 drivers from each semi final will progress up to the main final
- d) It is not allowed to drive a model car on any other place than the track and the marked track pit lane.

Proposal:

New 2.2.a/b With everybody qualifying for Christmas Tree sub-finals other than drivers qualifying directly for the "Main" Final.

The no. 1 ranked driver after completion of the qualifying heats will move up directly to the main final and take the pole position on the starting grid. The drivers ranked 2nd to 5th will compete in a "super-pole" final after completing the last Round of Qualifying. Each driver will drive the "super-pole" individually on the track, for 6 consecutive laps including warm-up . Procedure for Super Pole will be: 3 minutes warm up for each driver and then 6 consecutive laps. The "superpole" running order will be 5, 4, 3, 2. The driver that scores the fastest lap will also move up straight to the "Main" Final and take the second position on the starting grid. The other drivers from the "super-pole" will start in the semi-finals as per qualifying ranking.

This will replace 2.2.a and b (for touring cars only).

2.2.c The only change in this rule will be that not the first 5 are moving up to the final , but the first 4.

Remarks:

Explanation for this proposal is that we think it will bring more fun in qualifying and superpole will be fantastic. This rule is used in 1:8 and 1:10.... Drivers love it
More explanation at the EFRA AGM.

Proposed by NOMAC, Houtman Raymond

Seconded by: Portugal o Not Seconded

The proposal: o Passed Unanimously o Passed with 7 for, ...4. against and abstentions.

o Rejected with for, against and abstentions. o Amended

THE RULE SHOULD BE AMENDED TO READ:

Existing Rule: **4.1.**

ENGINE and FUEL

For Formula 1, Off Road and Fifth Scale Saloon:

1. Only one marked engine allowed. In exceptional circumstances the race director may allow a second engine during the time of a wet track. The marked engine maybe repaired/serviced and parts replaced except for the cylinder. If a second engine or a cylinder is replaced, the originals will be kept in race control until the end of the event. A driver changing engine will receive an automatic stop and go in his first final unless the first engine/ cylinder is shown to be beyond repair and outside the drivers control to Technical inspection. Each driver is only allowed to use a maximum of 2 engines per event.
2. The engine to be a single cylinder, 2 or 4 stroke, maximum 23ccm, maximum 26ccm for F1, 2wd, 4wd, and maximum 30 ccm for short course pull starter or external electric starter. Electric starters can only be used in the pitlane and under no circumstances to be used on the race-track. There must be a secure protection on the flywheel cover to prevent people touching the flywheel or moving parts.
3. No Turbo charging, Fuel injection, Supercharging, Wankel or rotary valve/ distribution engines are allowed.

4. All ignition must be mechanically fixed, only manual static adjustment is allowed. The flywheel can only have 1(one) pair of magnetic poles (ie one north and one south). There can only be a maximum of 2 coils (either a single combined LT and HT coil with the standard type ignition or two LT coils with the external ignition systems) working with the flywheel/rotor.

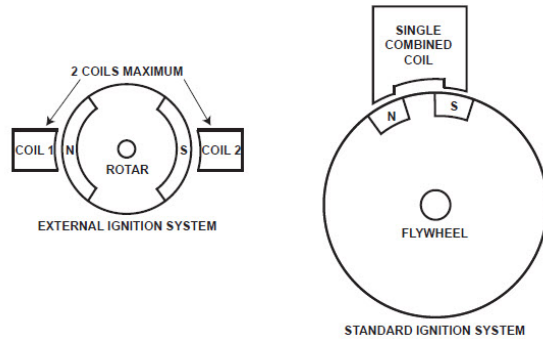

5. No Battery operated ignition allowed. Only a passive ignition system using R.P.M. as the single input parameter is allowed.

6. Only open deck admission ports are allowed. The removal of material is free as long as the modified shape of the transfer/admission port walls are in the direction of the cylinder bore at all times.
 7. The Cylinder block must be of a single casting. no independent liners or slipping liners are allowed.

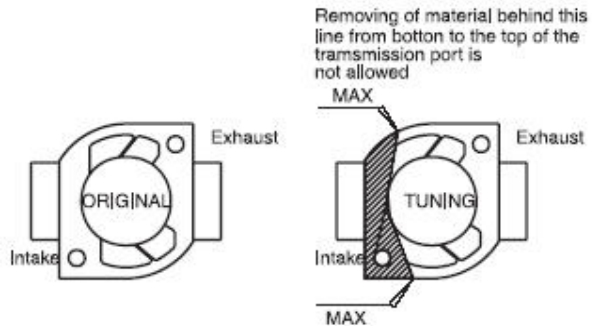

- 8. The maximum numbers of admission ports is limited to 4.
- 9. Engine must be air cooled. The air being driven directly by the flywheel.
- 10. The crankshaft must be of split shaft configuration, with enclosed big end. No half crankshafts allowed.
- 11. An air filter must be fitted to the carburettor.
- 12. The maximum venturi diameter of the carburettor is limited to 13 mm.
- 13. Only fuel admitted will be petrol normally available at street petrol stations. The fuel must be bought at a fuel Station within the vicinity of the event. Details of the fuel station location and opening times should be provided by the race organiser prior to the event commencement, Fuel testing should begin prior to the start of qualification. Special fuel's like Avgas, race fuel etc. are strictly forbidden. The only additive allowed is mass production two stroke oil.

Technical inspection may ask for a sealed bottle of that oil, to check it.
 If a fuel is found suspect, the driver will be asked to mix his fuel at technical inspection, so it can be verified.
 If an organiser is able to provide fuel at the track, all competitors have to use this fuel. The price of this fuel must not exceed the normal street price by more than 5%. Fuel tests may be made at random during the race. If a fuel is found illegal, the driver will be disqualified from the particular event and they will not be allowed to enter an EFRA large Scale event for the remainder of the current year and the full 12 months of the following year. The fuel tester must be available to the competitors during the event.
 If a driver wants to protest that decision, he has to make a written protest to EFRA with a deposit of 500.- EUR.
 All drivers that qualify for the semi finals will have their fuel tank capacity tested prior to the semi finals. After testing the fuel tank will be emptied, the drivers fuel container will be marked and remain in technical inspection (facilities permitting) until the driver/car is preparing to go out on track for their semi final and main final warm up. Only fuel from the drivers own marked fuel container is allowed to be used.

Proposal:

ENGINE and FUEL

For Formula 1, Off Road and Fifth Scale Saloon:

1. Only one marked engine allowed. In exceptional circumstances the race director may allow a second engine during the time of a wet track. The marked engine maybe repaired/serviced and parts replaced except for the cylinder. If a second engine or a cylinder is replaced, the originals will be kept in race control until the end of the event. A driver changing engine will receive an automatic stop and go in his first final unless the first engine/ cylinder is shown to be beyond repair and outside the drivers control to Technical inspection. Each driver is only allowed to use a maximum of 2 engines per event.

2. The engine to be a single cylinder, 2 or 4 stroke,

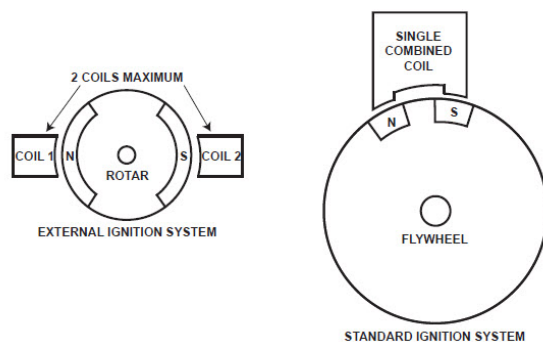

maximum 23ccm, maximum 26ccm for F1, 2wd, 4wd, and maximum 30 ccm for short course pull starter or external electric starter. Electric starters can only be used in the pitlane and under no circumstances to be used on the race-track. There must be a secure protection on the flywheel cover to prevent people touching the flywheel or moving parts.

3. No Turbo charging, Fuel injection, Supercharging, Wankel or rotary valve/ distribution engines are allowed.

4. All ignition must be mechanically fixed, only manual static adjustment is allowed. The flywheel can only have 1(one)pair of magnetic poles (ie one north and one south)

-1. **Touring cars and F1**;- There can only be a maximum of 2 coils (either a single combined LT and HT coil with the standard type ignition or two LT coils with the external ignition systems) working with the flywheel/rotor.

-2. **Off Road**;- Only the standard Zenoah car engine type/size of ignition systems can be used.

5. No Battery operated ignition allowed. Only a passive ignition system using R.P.M. as the single input parameter is allowed.

6. Only open deck admission ports are allowed. The removal of material is free as long as the modified shape of the transfer/admission port walls are in the direction of the cylinder bore at all times.

7. The Cylinder block must be of a single casting. no independent liners or slipping liners are allowed

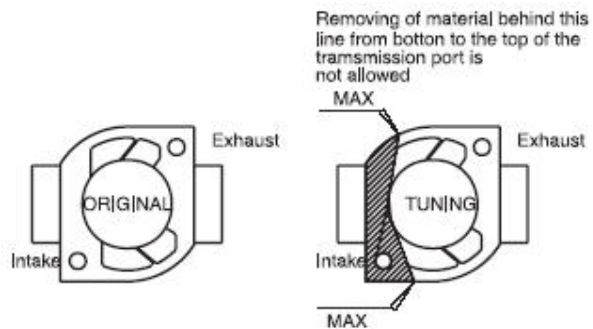

8. The maximum numbers of admission ports is limited to 4.

9. Engine must be air cooled. The air being driven directly by the flywheel.

10. The crankshaft must be of split shaft configuration, with enclosed big end. No half crankshafts allowed.

11. An air filter must be fitted to the carburettor.

12. The maximum venturi diameter of the carburettor is limited to 13 mm.

13. Only fuel admitted will be petrol normally available at street petrol stations. The fuel must be bought at a fuel Station within the vicinity of the event. Details of the fuel station location and opening times should be provided by the race organiser prior to the event commencement, Fuel testing should begin prior to the start of qualification. Special fuel's like Avgas, race fuel etc. are strictly forbidden. The only additive allowed is mass production two stroke oil.

Technical inspection may ask for a sealed bottle of that oil, to check it.

If a fuel is found suspect, the driver will be asked to mix his fuel at technical inspection, so it can be verified.

If an organiser is able to provide fuel at the track, all competitors have to use this fuel. The price of this fuel must not exceed the normal street price by more than 5%. Fuel tests may be made at random during the race. If a fuel is found illegal, the driver will be disqualified from the particular event and they will not be allowed to enter an EFRA large Scale event for the remainder of the current year and the full 12 months of the following year. The fuel tester must be available to the competitors during the event.

If a driver wants to protest that decision, he has to make a written protest to EFRA with a deposit of 500.- EUR.

All drivers that qualify for the semi finals will have their fuel tank capacity tested prior to the semi finals. After testing the fuel tank will be emptied, the drivers fuel container will be marked and remain in technical inspection (facilities permitting) until the driver/car is preparing to go out on track for their semi final and main final warm up. Only fuel from the drivers own marked fuel container is allowed to be used.

Remarks:

Only allow the standard zenoah type of ignition system to be used in all off road classes. The words 'type/size' is so the rule includes similar products from other manufacturers such as CY etc. Reduces cost, increases engine life span and reliability.

Proposed by EFRA, Oddie Ian

Seconded by:BRCA o Not Seconded

The proposal: X Passed Unanimously o Passed with for, against and abstentions.

o Rejected with for, against and abstentions. o Amended

THE RULE SHOULD BE AMENDED TO READ:

Existing Rule: **4.2.1.**

Maximum noise level is 81dB (A) measured at 10 metres, 1 metre above the track.

The race director has the authority to decide a different method of measuring (using the EFRA noise trap) as long, as the result will be the same.

If a cars average over 10 or more laps exceeds +1dB (A) for On Road cars and +4dB(A) for Off Road cars higher than the limit during the qualifying then the driver will loose their best qualifying result. If this level is exceeded during a final then the penalty is a 1 lap deduction at the end of that final. Under exceptional circumstances common sense will be used.

Both the Race Director and Referee's can decide if any car producing excessive noise is allowed to race.

Exhausts have to be of minimum three chamber type. No open exhausts or pipes are allowed.

The total exhaust must be inside the body, with the exception of the tailend of the pipe, which may protrude the body by no more than 10 mm.

No adjustable or moving parts are allowed in the manifold or muffler. The body may be cut out at that point max. 20 mm more than the tailend diameter.

Max. inside diameter tail end 13 mm.

Proposal:

Maximum noise level is 81dB (A) measured at 10 metres, 1 metre above the track.

The race director has the authority to decide a different method of measuring (using the EFRA noise trap) as long, as the result will be the same.

If a cars average over 10 or more laps exceeds **the limit (with an additional +4dB(A) for Off Road and F1 cars)** during the qualifying then the driver will loose their best qualifying result. If this level is exceeded during a final then the penalty is a 1 lap deduction at the end of that final. Under exceptional circumstances common sense will be used.

Both the Race Director and Referee's can decide if any car producing excessive noise is allowed to race.

Exhausts have to be of minimum three chamber type. No open exhausts or pipes are allowed.

The total exhaust must be inside the body, with the exception of the tailend of the pipe, which may protrude the body by no more than 10 mm.

No adjustable or moving parts are allowed in the manifold or muffler. The body may be cut out at that point max. 20 mm more than the tailend diameter.

Max. inside diameter tail end 13 mm.

Remarks:

Finally remove the extra tolerance for touring cars, now 81db. Add in +4db tolerance for the F1 class. None of the F1 cars could pass the db limit for the touring cars at the EC this year, so the extra +4db will give manufacturers time to develop better air boxes/pipes. The efra db testing software has now been updated so several classes can be run at the same event with differing noise limits

Proposed by EFRA, Oddie Ian

Seconded by: .Croatia..... o Not Seconded

The proposal: X Passed Unanimously o Passed with for, against and abstentions.

o Rejected with for, against and abstentions. o Amended

THE RULE IS NEW:

Existing Rule: **4.4.**

Proposal:

4.4.1 At all EFRA races (Grand Prix, European Championship), maximum two sets (4 pairs=2 sets) of tyres are allowed for all qualification rounds. All tyres must be marked and recorded in a book by technical inspection. Tyre inspection must be provided after every qualification round. Eventual tyre change with a new one will be allowed only in a case of visible physical damage due to crash or accident. In case of rain an extra rain tyre set is allowed - use of a repair tyres leads to a stop and go penalty or start from the last position in the grid in the first sub final.

Remarks:

Purpose of this proposal is to equal driver competitiveness, limit possible advantage gain by using more tyre pairs

Proposed by HAMS, Matosic Zvonimir

Seconded by: o **Not Seconded**

The proposal: o Passed Unanimously o Passed with for, against and abstentions.

o Rejected with for, against and abstentions. o Amended

THE RULE SHOULD BE AMENDED TO READ:

Existing Rule: **5.3.2.**

All 1:5 cars have to be genuine scale in all details and proportions and be a fully detailed model of an existing 1:1 touring race car. If the allowed tolerances are used, then all parts of the model in that particular view have to be within the same sign (wheelbase-, length,- //wheelbase+, length+). Mixtures of car designs are not allowed.

The minimum length of a Super Touring Car is 4.200 mm that gives a minimum length of 798 mm in scale including max.-tolerance.

All recognized cars must have a minimum length of 4.200 mm/165.35 in. All bodies that are produced world-wide, descend from a original touring car racing and are commercially available, under consideration of Paragraph 5.3, will be allowed.

Only bodysells that are approved by EFRA will be allowed to race in EFRA sanctioned events. The EFRA-homologation number has to be permanently engraved or moulded in within the space normally used for car-registration numbers at the rear end of the model.

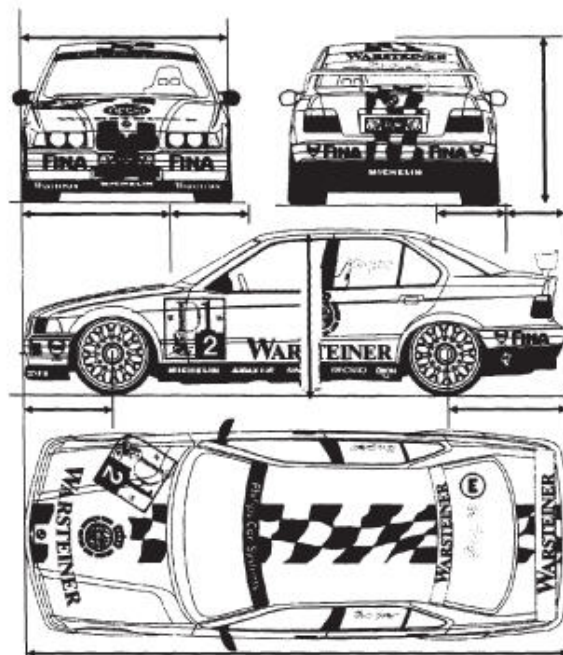

Proposal:

All **All** 1:5 cars have to be genuine scale in all details and proportions and be a fully detailed model of an existing 1:1 touring race car. If the allowed tolerances are used, then all parts of the model in that particular view have to be within the same sign (wheelbase-, length,- //wheelbase+, length+). Mixtures of car designs are not allowed.

The minimum length of a Super Touring Car is 4.200 mm that gives a minimum length of 798 mm in scale including max.-tolerance.

All recognized cars must have a minimum length of 4.200 mm/165.35 in. All bodies that are produced world-wide, descend from a original touring car racing and are commercially available, under consideration of Paragraph 5.3, will be allowed.

Only bodysells that are approved by EFRA will be allowed to race in EFRA sanctioned events. The EFRA-homologation number has to be permanently engraved or moulded in within the space normally used for car-registration numbers at the rear end of the model. **The minimum weight of the body is 500g (ready to race including wing but excluding any air ducting). Weights are NOT allowed to be added to the body.**

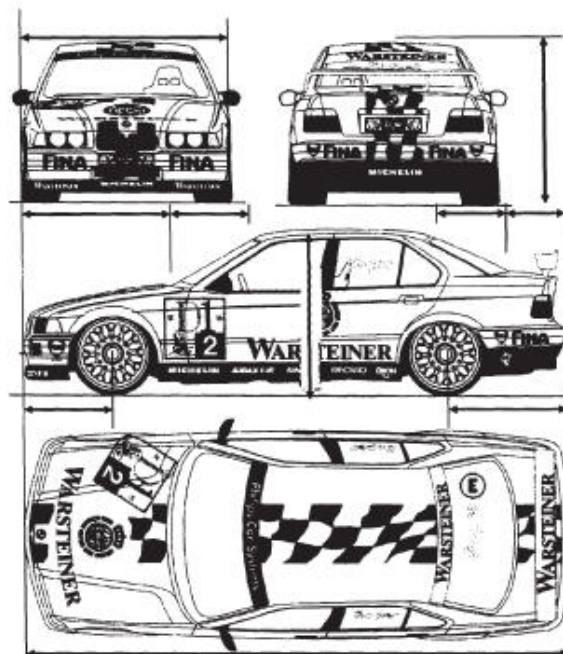

Remarks:

Add in a minimum body weight of 500g to prevent the use of bodies that are thinner than 1mm. Extremely thin bodies have a very short life span for most drivers.

Proposed by EFRA, Oddie Ian

Seconded by: .BRCA..... o Not Seconded

The proposal: o Passed Unanimously o Passed with .10... for, against and1 abstentions.
o Rejected with for, against and abstentions. o Amended

THE RULE SHOULD BE AMENDED TO READ:

Existing Rule: 5.3.5.

WING/SPOILER

A single rear wing is permitted as long as it does not exceed the front view profile and the length of the car. The wing has to fit in a side "profile box" measuring 60 mm x 60 mm per side and should not overhang the end of the car.



Proposal:

WING/SPOILER

A single rear wing is permitted as long as it does not exceed the front view profile and the length of the car. The wing has to fit in a side "profile box" measuring 60 mm x 60 mm per side and should not overhang the end of the car. **Extension pieces extending past the main end plates are not allowed**

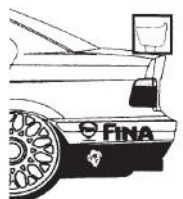

Remarks:

Any extensions to widen the standard wing are not allowed.

Proposed by EFRA, Oddie Ian

Seconded by: .Croatia..... o Not Seconded

The proposal: X Passed Unanimously o Passed with for, against and abstentions.
o Rejected with for, against and abstentions. o Amended

THE RULE SHOULD BE AMENDED TO READ:

Existing Rule: 5.3.6.

A bumper has to be fitted to the chassis. Bumpers have to be designed in a way that they fill the front of a car body completely and be a minimum height of 40mm. The material used has to be flexible like PU-RIM or other foams, that are used in 1:1 car construction to absorb impact energy. At no point may any part of inflexible material for bodyshell mounting protrude from the body more than 10mm.

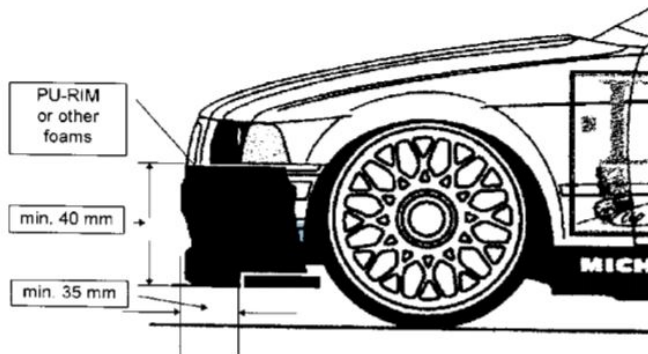

Proposal:

A bumper has to be fitted to the chassis. Bumpers have to be designed in a way that they fill the front of a car body completely and be a minimum height of 40mm. The material used has to be flexible like PU-RIM or other foams, that are used in 1:1 car construction to absorb impact energy. At no point may any part of inflexible material for bodyshell mounting protrude from the body more than 10mm. If an opening is created through the foam bumper for cooling air, the combined thickness of the foam (above and below the cooling hole/slot) must still be a minimum of 40mm in height.

Remarks:

Holes or slots are permitted in the foam bumper for cooling but the overall combined height of 40mm must remain.

Proposed by EFRA, Oddie Ian

Seconded by: .Croatia..... o Not Seconded

The proposal: x Passed Unanimously o Passed with for, against and abstentions.

o Rejected with for, against and abstentions. o Amended

THE RULE SHOULD BE AMENDED TO READ:

Existing Rule: **5.3.7.**

TYRES

Rim Diameter max.:	107 mm
Rim and fitted tyre Diameter:	max.: 136 mm
Rim and fitted tyre width - front	max.: 75 mm
Rim and fitted tyre width - rear	max.: 80 mm

Only semi pneumatic rubber is allowed. Foam tires are not allowed.

Proposal:

TYRES

Rim Diameter max.:	107 mm
Rim and fitted tyre Diameter:	max.: 136 mm
Rim and fitted tyre width - front	max.: 75 mm
Rim and fitted tyre width - rear	max.: 80 mm

Only semi pneumatic rubber is allowed. Foam tires are not allowed

5.3.8 Electric Touring Cars,

Introduce Electric touring cars into the GP series for 2018, run as a separate class

Minimum Weight 11Kg

Maximum Battery Size 25Ah, 8s.

The same battery size must be used during qualifying and finals.

Semi Finals and Main Final 20 minutes duration.

Bumpers, bodies, wings, tyres etc as per the engine driven touring cars

Remarks:

Introduce some basic rules for the introduction of Electric touring cars to run in the Gp series. This will be used to gauge interest for future rule refinement and possible inclusion as an EC class. It's important to embrace new technology within our class, and a clean quiet class might encourage new racers into our section.

Proposed by EFRA, Oddie Ian

Seconded by: .Croatia..... o Not Seconded

The proposal: X Passed Unanimously o Passed with for, against and abstentions.

o Rejected with for, against and abstentions. o Amended

THE RULE SHOULD BE AMENDED TO READ:

Existing Rule: **5.3.7.**

TYRES

Rim Diameter max.:	107 mm
Rim and fitted tyre Diameter:	max.: 136 mm
Rim and fitted tyre width - front	max.: 75 mm
Rim and fitted tyre width - rear	max.: 80 mm

Only semi pneumatic rubber is allowed. Foam tires are not allowed.

Proposal:

TYRES

Rim Diameter max.:	107 mm
Rim and fitted tyre Diameter:	max.: 136 mm
Rim and fitted tyre width - front	max.: 75 mm
Rim and fitted tyre width - rear	max.: 80 mm

Only semi pneumatic rubber is allowed. Foam tires are not allowed.

For European Championships, each manufacturer must nominate 4 compounds of wheels-tyres-insert to the Efra Chairman a minimum of 28 days prior to the start of the event.

One of the nominated compounds must be a wet weather tyre. These must be available through distributors and the list will be published on the Efra web site.

Only these tyres will be allowed to be used during timed practice, qualifying and finals. At the event each manufacturer will give one pair of wheels/tyres of each nominated compound to Technical inspection to be used as reference and control tyres.

These tyres can also be marked and exchanged (of the same compound) with any chosen driver to use during qualifying or finals (in due time for preparation/tyre warming etc). Any tyres remaining at the end of the event will be returned to the manufacturers.

Any driver found to be running any other compounds will be disqualified from that qualifying heat or final as appropriate.

Remarks:

During this years EC there were many debates on tyres and controls to stop the use of special tyres/wheels etc. The proposal is intended to ensure every driver has the same tyres available to them and no one is using anything 'special'. The option for technical inspection to exchange a control tyre/s with drivers reduces the chance of them risking using anything but the nominated compounds.

Proposed by EFRA, Oddie Ian

Seconded by: .NOMAC..... o Not Seconded

The proposal: X Passed Unanimously o Passed with for, against and abstentions.

o Rejected with for, against and abstentions. o Amended

THE RULE SHOULD BE AMENDED TO READ:

Existing Rule: **5.4.9.**

Chassis, Body measurements

Only original large scale lexan body shells are allowed

The body must be fully painted except for the windows

Motorstop access must be easy .

The chassis must be flat underneath and no screws may extendCar size

2wd & 4wd buggy

Max length	820 mm
Max width	480 mm with full compressed suspension
Max height	360 mm with full compressed suspension
Short course truck:	
Min length	850 mm
Max lenght	1000 mm
Min width	480 mm
Max width	530 mm with full compressed suspension
Min height	300 mm

Max height	350 mm with full compressed suspension
Min wheel base	600 mm
Max wheel base	650 mm

Proposal:

Chassis, Body measurements

Only original large scale body shells are allowed

The body must be fully painted except for the windows

Short Course bodies must cover the wheels

Motorstop access must be easy .

The chassis must be flat underneath and no screws may extend Car size

2wd & 4wd buggy

Max length	820 mm
Max width	480 mm with full compressed suspension
Max height	360 mm with full compressed suspension

Short course truck:

Min length	850 mm
Max length	1000 mm
Min width	480mm Track measured at full suspension ride height
Max Width	530 mm Track with fully compressed suspension
Min height	300 mm
Max height	350 mm with full compressed suspension
Min wheel base	600 mm
Max wheel base	650 mm

Remarks:

Remove 'lexan' only for the body shells. Short Course bodies must cover the wheels. Short course min/max width clarified as being the track of the car wheels and the minimum measured at full suspension drop..

Proposed by EFRA, Oddie Ian

Seconded by: .BRCA..... o Not Seconded

The proposal: X Passed Unanimously o Passed with for, against and abstentions.

o Rejected with for, against and abstentions. o Amended

9. ELECTION OF VICE SECTION CHAIRMAN.

Election of Chairman: Ian Oddie is willing to re-stand re-elected unanimously.

10. ANY OTHER BUSINESS

11. ITEMS FOR GENERAL DISCUSSION.

The Section Chairman thanked all participants for a constructive meeting, and being no further business the meeting was closed at 16:40